

## ■ SCORPIO BATTERY | CORDLESS PROGRAMMABLE WELDING TRACTOR

The SCORPIO BATTERY is a battery-powered, programmable welding tractor designed for producing fillet and butt welds in both stitch and continuous welding modes. Its programming function allows you to set the desired welding path by specifying parameters such as weld length, skip length as well as crater filling at the beginning and the end of the welds.

The CAS LiHD (High Density Lithium Ion) battery provides sufficient power for handling even the toughest applications without the need for cables.

Travel speed control and stabilization enable precise matching of weld bead geometry to required specifications, reducing costly over-welding and significantly decreasing filler metal consumption.

The SCORPIO BATTERY can also produce weave welds with the use of an optional pendulum oscillator, which allows for precise control of weave width, weave speed, and left/right side dwell times.

### ■ Features and benefits:

- Simple and ergonomic programming of welding patterns and stitch welding parameters
- Multifunctional LED display presenting travel speed, units, welding settings, and diagnostic messages
- Closed-loop speed control system stabilizes travel speed, enabling uniform heat input for consistently high-quality welds
- Convenient 18 V DC battery supply (the same 4.0 Ah battery for MINI SPIDER BATTERY, GECKO BATTERY and DRAGON BATTERY tractors)
- High Density Lithium Ion battery (LiHD) ensures maximum power availability for extended periods
- Intelligent battery management for long-lasting performance
- 4-wheel drive system with magnetic traction for stable movement of the tractor
- Compact, lightweight design with durable aluminum cast housing
- Optional pendulum oscillator for producing weave welds
- Auxiliary accessories make SCORPIO BATTERY suitable for various applications with carbon steel, stainless steel and aluminium
- Equipped with limit switches



Continuous welding



Stitch welding



Welding path programming



Dual torch welding



Dual Arc Ignition

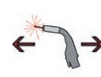

Horizontal speed  
5-130 cm/min  
(1-51 in/min)



Min. path concave  
radius  
1250 mm (49 7/32")



Min. path convex  
radius  
1000 mm (39 3/8)



Weight  
7 kg (15.4 lbs)

## Programmable variables diagram

Simple and ergonomic programming of welding patterns and stitch welding by specifying parameters such as weld length, skip length and crater filling at the beginning and the end of the welds.

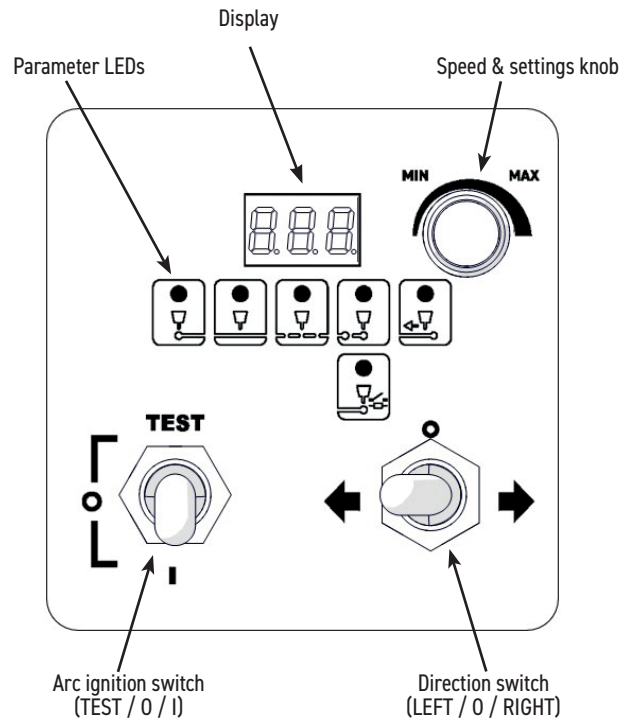

Crater filling times

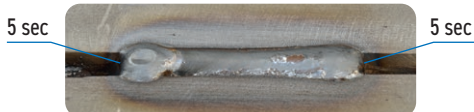

Back weld 5 mm



	Crater fill time Arc stabilization time	AST 0-5.0 sec [step: 0.1] Crater filling time at the beginning of the weld
	Weld length	0.5-99.9 cm [step: 0.1] 0.5-40" [step: 0.1]
	Skip length	--- 0.5-99.9 cm [step: 0.1] 0.5-40" [step: 0.1]
	Crater fill	CF CFP 0-5.0 sec [step: 0.1] Crater filling time at the end of the weld
	Off (default) On	OFF ON Current curve set on Welding Source Full current from Welding Source
	Reverse filling length	-b- 0-2 cm [step: 0.1] 0-1" [step: 0.1]
	All LEDs on Total length	1-999 cm [step: 1] 1-400" [step: 1] INF

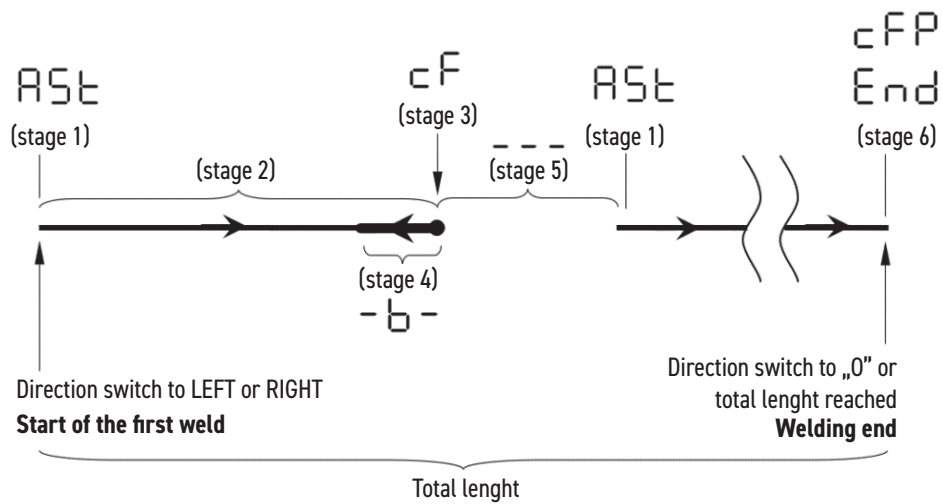
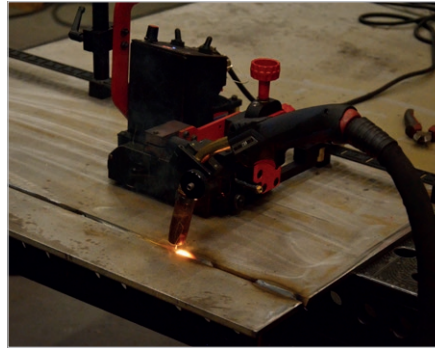

Stage 1	Arc stabilization and crater filling at the beginning of the weld
Stage 2	Tractor moves with the set speed and creates the weld of a defined length
Stage 3	Crater filling at the end of the weld
Stage 4	Back weld (Reverse filling length)
Stage 5	Tractor skips between welds. Next steps 1, 2, 3, 4 and 5 are repeated until total length is reached
Stage 6	Final crater filling (the end of welding procedure)



## Standard accessories



Battery 4.0 Ah  
AKM-0738-10-00-01-0  
(2 pcs included)



Dual arc ignition cable of 6.5 m (21 ft)  
KBL-0466-17-00-00-0



Standard guide arms (set of 2 pcs)  
ZST-0752-17-00-00-0



Ultra-short rod torch holder with clamp 16-22 mm  
UCW-0757-09-00-00-0

## Optional accessories for variety of applications



Torch clamp 16-22 mm  
ZRZ-0752-07-01-00-0



Torch clip 16-22 mm  
ZCS-0476-06-01-00-0



Torch clamp 22-35 mm  
ZRZ-0466-19-00-00-0



Short Rod Clamp  
WLK-0476-20-01-00-0



Short rod torch holder with clip 16-22 mm  
UCW-0476-27-00-00-0



Long Rod Clamp  
WLK-0466-04-10-00-0



Short rod torch holder with clamp 16-22 mm  
UCW-0754-07-00-00-0



Long rod torch holder with clip 16-22 mm  
UCW-0466-22-00-00-0



Long rod torch holder with clamp 16-22 mm  
UCW-0752-07-00-00-0

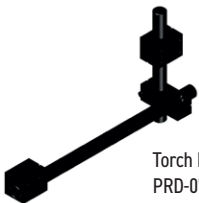

Torch Extension Arm  
PRD-0757-10-00-00-0



Torch Holder Lower Rod Clamp Assembly  
UCW-0476-06-00-00-0

Extended cross-slide 0-76 mm (0-3") either up-down or left-right  
ZSP-0466-46-00-00-1



Battery Charger  
LDW-0738-10-00-30-0 (EU)  
LDW-0738-04-00-30-0 (UK)

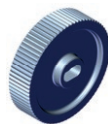

Stainless steel driving wheel  
KOL-0466-72-00-00-0



Cable anchor  
PDT-0776-04-00-00-0



Dual Torch Mount  
PDT-0466-40-00-00-0

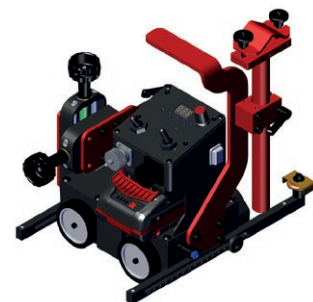
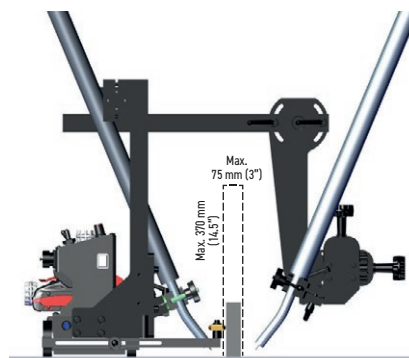

**Pendulum oscillation (option)**

SCORPIO BATTERY is ready for use with the OSC-8 and OSC-8 PRO external pendulum oscillators and has built-in socket to power these oscillators. This eliminates the need for a separate oscillator power supply.



Weave welder OSC-8  
OSC-0497-10-00-00-0

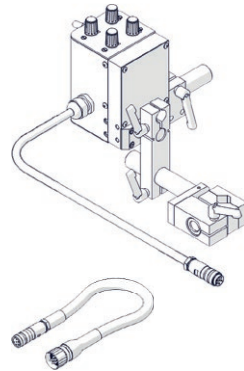

Cable adapter  
PWD-0654-10-00-00-0



Weave welder OSC-8 PRO  
OSC-0799-10-00-00-0

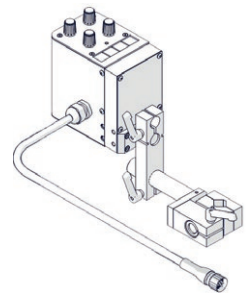

**The following oscillation parameters can be set and adjusted with both pendulum weave welders:**

- oscillation width
- oscillation speed
- dwell time on both ends

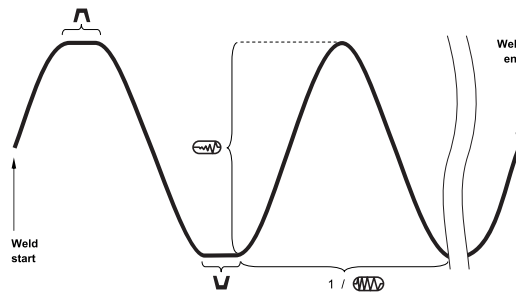

Oscillator support:  
(including two M6x14 screws)  
WSP-0757-11-01-00-0

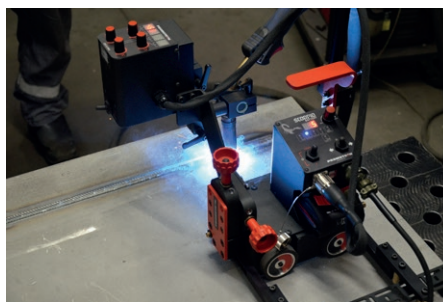
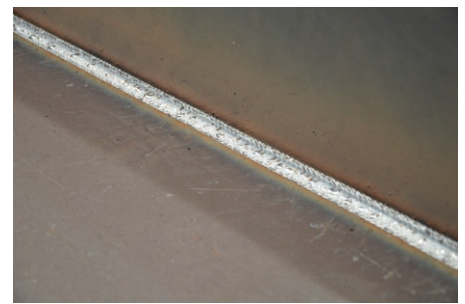
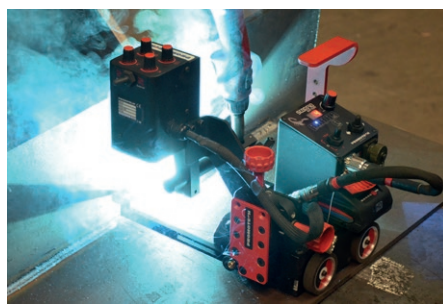
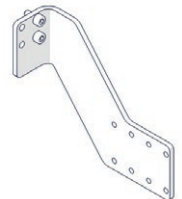

TECHNICAL SPECIFICATION	OSC-8	OSC-8 PRO
Voltage	14-24 V DC	18-24V DC
Power	50 W	50 W
Torch type	MIG/MAG	MIG/MAG
Torch diameter	16-22 mm (5/8-7/8")	16-22 mm (5/8-7/8")
Oscillation type	Pendulum	Pendulum
Oscillation width at r=150 mm (6")	1-30 mm (1-100%)1/32-1-3/16" (1-100%)	1-30 mm (3%-99%)1/32-1-3/16" (3-99%)
Oscillation speed at oscillation width of 10 mm (3/8") and zero dwell time on ends	12-115 cycles/min (1-100%)	12-300 cycles/min
Oscillation dwell time on ends	0-3 s	0-3 s
Maximum torque	8 N·m (5.7 lb-ft)	8 N·m (5.7 lb-ft)
Required ambient temperature	0-50°C (32-122°F)	0-50°C (32-122°F)
Weight	2 kg (4.4 lbs)	2.1 kg (4.6 lbs)
Product code:	OSC-0497-10-00-00-0	OSC-0799-10-00-00-0

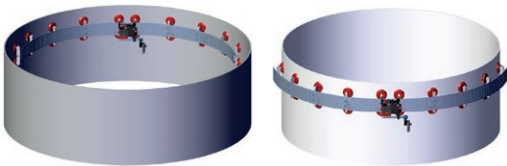

Vacuum units in use on stainless steel or aluminum tanks

Flexible trackway length 1.88 m (6.1 ft).  
Minimum curvature radius of 1.25 m (4.1 ft)  
PRW-0466-71-00-00-0

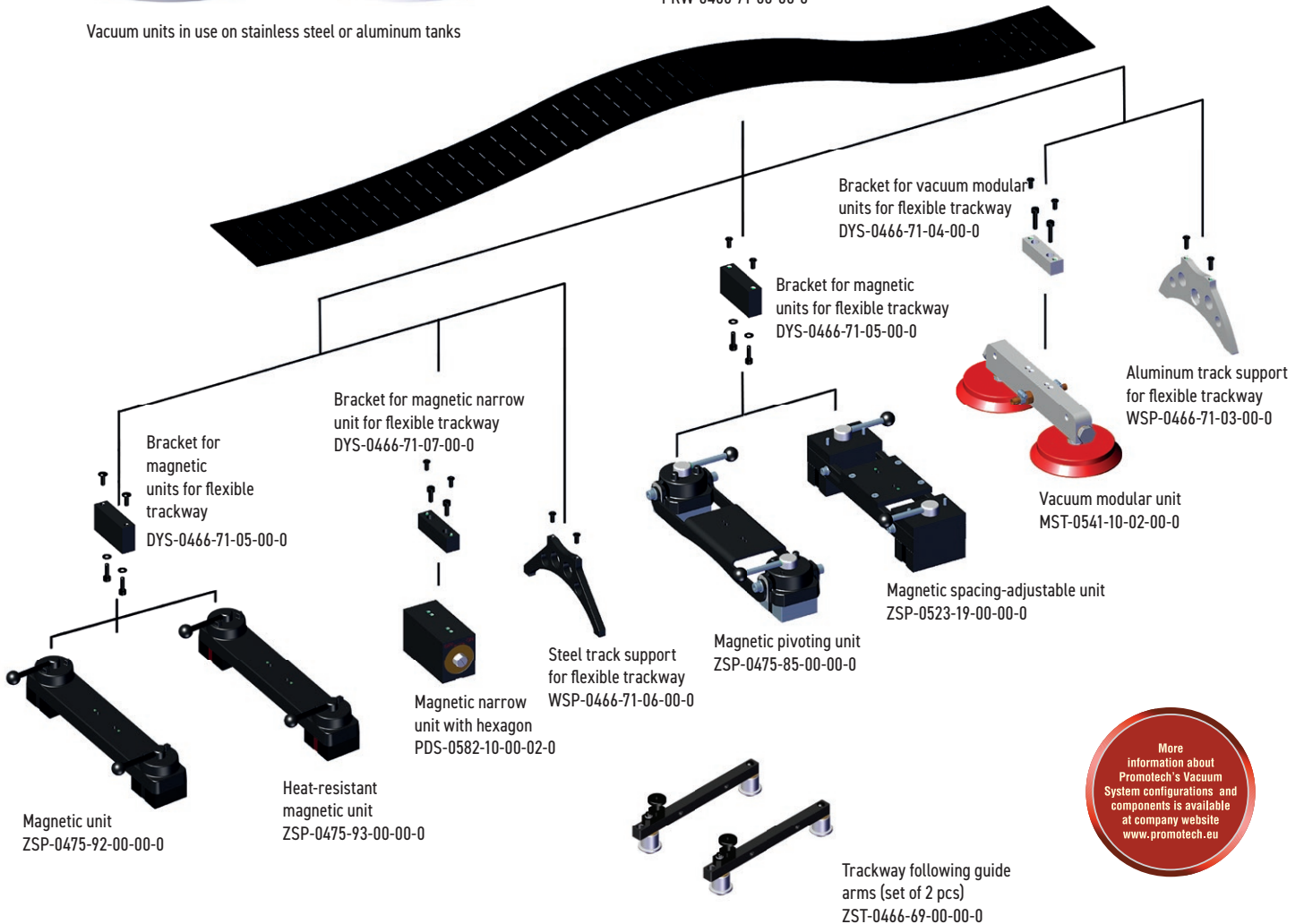



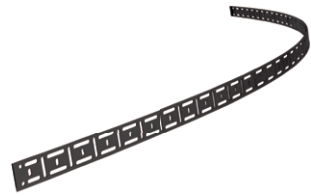
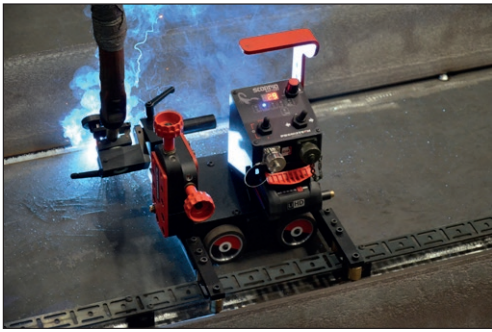

Flexible track length 185cm (6ft) 1pc  
Minimum curvature radius of 1.0 m (3.3 ft)  
PRW-0466-50-01-01-0



Magnetic block for flexible track  
box of 10 pcs  
BLO-0466-68-00-00-0

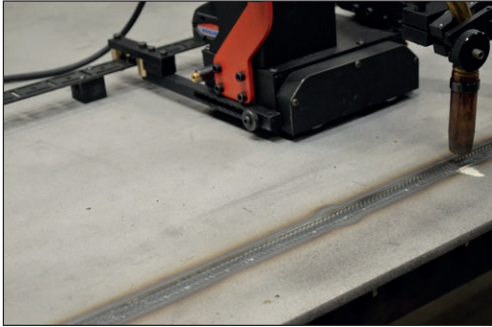

Guide adjustment tool to position the track  
parallel to the edge  
UST-0466-53-00-00-0

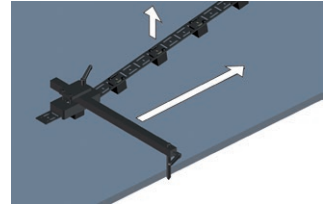

Depending on sort of fixing units in use with flexible trackway, Scorpio Battery welding tractor is suitable for applications with carbon steel, stainless steel and aluminum.



Low guide arms (set of 2 pcs)  
PRW-0752-12-00-00-0

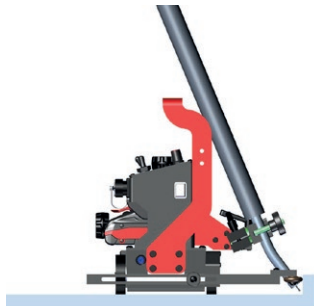

High guide arms (set of 2 pcs)  
PRW-0752-13-00-00-0



Adjustable guide arms (set of 2 pcs)  
PRW-0752-10-00-00-0

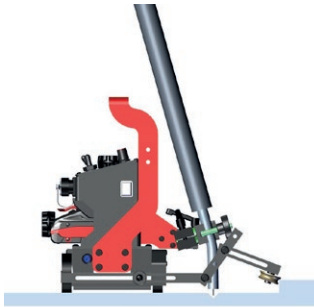

Magnet guide arms (set of 2 pcs)  
PRW-0752-11-00-00-0

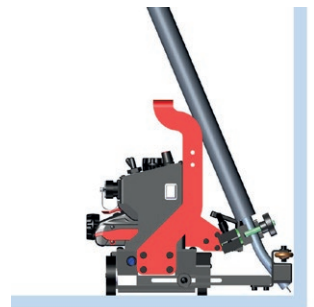

Track following guide arms (set of 2 pcs)  
PRW-0752-14-00-00-0



SCORPIO BATTERY TECHNICAL SPECIFICATION		
Voltage		18 V DC, 4 Ah
Power		18 W
Welding position (according to EN ISO 6947 and AWS/ASME)		PA/1F/1G PB/2F PC/2G
Minimum path curve radius	Outer	1000 mm (39 3/8")
	Inner	1250 mm (49 7/32")
Torch type		MIG/MAG
Torch diameter		16–22 mm (5/8"–55/64") up to 35 mm (1.38") option
Minimum workpiece thickness		4 mm (5/32")
Ground clearance		4 mm (5/32")
Horizontal pulling force		150 N
Horizontal speed (with a fully charged battery)		5–130 cm/min (1–51 in/min)
Weight (without the battery)		7 kg (15.4 lbs)
Maximum torch reach		70 mm (2 3/4")
Product code		WOZ-0757-10-00-00-0

\* With battery fully charged

## Dimensions:

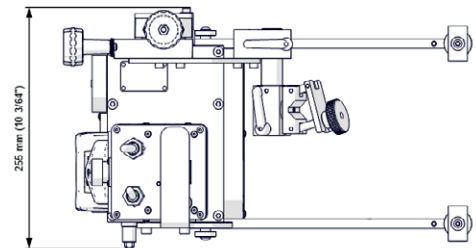
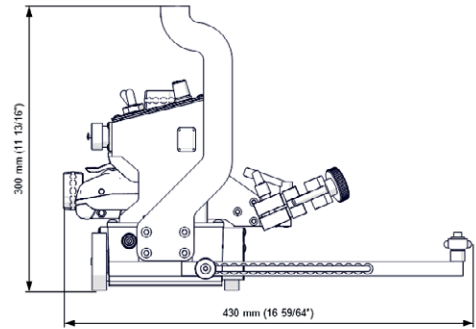

## New control system of battery pack:

### Detection and supervised parameters:

- too low and too high voltage
- too low and too high temperature
- failure of the temperature sensor
- internal battery failure

### Benefits:

- over discharge protection
- extended battery life
- high level of safety for both tractor and operator



## Standard shipping set:

- Tractor
- Plastic box
- Battery 4.0 Ah (2 pcs included)
- Torch holder
- Arc ignition cable
- 4 mm hex wrench
- 3 mm hex wrench
- Operator's manual



Min. path convex radius 1000 mm

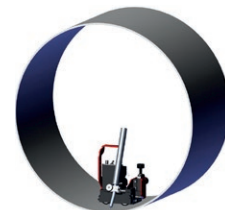

Min. path concave radius 1250 mm

More information on [www.promotech.eu](http://www.promotech.eu)



American Welding Society  
Supporting Company Member

Mitglied im DVS – Deutscher Verband für Schweißen und verwandte Verfahren e. V.



All information is subject to change without notice. 24.09



PROMOTECH Sp. z o.o.  
ul. Elewatorska 23/1, 15-620 BIAŁYSTOK, POLAND  
tel. (+48 85) 678 34 05, fax (+48 85) 662 78 77  
marketing@promotech.eu www.promotech.eu

Your local dealer:

