



4-IN-1™ Utility Clamping System

The most versatile Sliding Arm Clamps in the market.



Ergonomic Comfort Handle with purchase of G / M Rail clamps.

UM Models:
Plastic handle ONLY
UG Models:
Plastic Handle + Cap

Removable / Reversible Clamp Arm

Standard Pad



Replaceable Heavy Duty Pad

Self-aligning

Extender Block

V-Pad

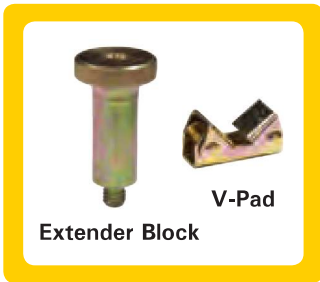

4-IN-1 ACCESSORY PACK

The 4-IN-1 Clamp Kit comes complete with the V-Pad and Extender Block accessories.

(See page 40 for details.)

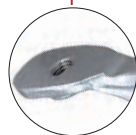

Tapped Hole

For attaching accessories such as the V-Pad or Extender Block.



UE,UF,UG,UM Models:
Press the Spring Stop to slide the clamp arm ON & OFF



UD Models:
Remove the Key Ring.

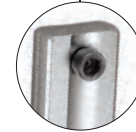

UP Models:
Remove the Screw Stop.

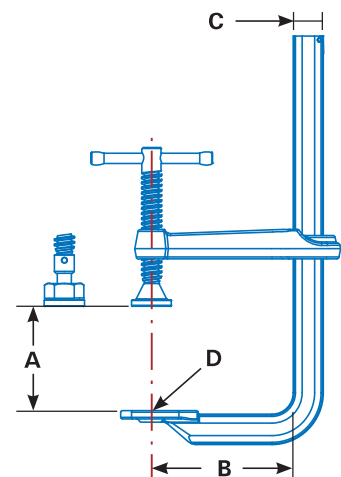

Optional Slide-on SIDEKICKS

Mount onto Clamps for the 2nd axis clamping.

(See page 40 for details.)

ONE Clamp... FOUR functions.

The strong, economical 4-IN-1 Utility Clamps adapt to serve four different applications.



1. Standard

Sliding Arm Clamps are 10x faster than a C-Clamp!



2. Pipe

Add the exclusive V-Pad to create a Pipe Clamp!

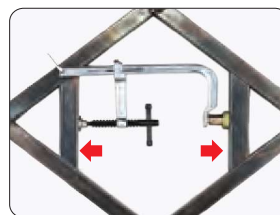

3. Spreader

Reverse the clamp arm and create a Spreader Clamp.



4. Step-Over

Add the Extender Block to create a Step-Over Clamp.

All Strong Hand Tools® Utility Clamps are made of high quality heat treated steel and nickel / chrome plated for strength and durability.



LIGHT & MEDIUM DUTY

Clamping Pressure: 230 - 550 kg
Standard Pads



UD Series with Key Ring Stop



UE, UF, UG Series with Spring Stop

Part No.	Capacity - A (mm)	Throat Depth - B (mm)	Clamping Pressure (kg)	Rail Size - C (mm)	Tapped Hole - D	Weight (kg)
UD45M	115	83	230	16 x 8	M8	0.5
UD65M	165	83	230	16 x 8	M8	0.5
UD85M	216	83	230	16 x 8	M8	0.6
UE85M	216	100	380	20 x 10	M10	1.0
UE125M	318	100	380	20 x 10	M10	1.2
UF65M	165	120	450	22 x 11	M10	1.1
UF100M	255	120	450	22 x 11	M10	1.3
UG85M	216	120	550	25 x 12	M10	1.6
UG125M	318	120	550	25 x 12	M10	1.8
UG205M	521	120	550	25 x 12	M10	2.2
UG1257M	318	178 * Deep Throat	450	25 x 12	M10	2.3
UG1657M	419	178 * Deep Throat	450	25 x 12	M10	2.5

J-CLAMP STEP-OVER



UD, UF, UG Series



UM Series

* Heavy Duty Replaceable Pads

Part No.	Capacity - A (mm)	Throat Depth - B (mm)	Clamping Pressure (kg)	Rail Size - C (mm)	Tapped Hole - D	Weight (kg)
UD45JM	115	83 (50)	230	16 x 8	M10	0.6
UF100JM	254	120 (75)	450	22 x 11	M10	1.5
UG105JM	267	120 (100)	550	25 x 12	M10	2.3
UM125JM	320	140 (100)	1,100	32 x 14	M10	3.7
UM205JM	521	140 (100)	1,100	32 x 14	M10	4.2